



AIRSTRIP®

AIRSTRIP® IS DESIGNED TO DAMPEN NOISE AND VIBRATION



Vibration Dampening

- Available in 10' lengths
- Santoprene UL94HB rated
- Made in USA
- Excellent Protection from Vibration
- Prevents Galvanic Corrosion
- Perfect Addition to Duct Supports
- Light Weight, Dependable, & Long Lasting
- Temperature Range of
-40°F to 250°F (-40°C to 121°C)



ZSIINC.COM | 800-323-7053

ZSi & Wesanco are part of the Ideal Tridon Group. Learn more at idealtridongroup.com



The AIRSTRIP is designed to dampen the noise and vibration that can occur between piping or duct work and the supporting channel. Made from 64 durometer Santoprene, the AIRSTRIP is light weight, dependable, and long-lasting.

Part No.	Max. Load Lbs. per Lineal In.		Length		Wt. Each per 10' peice	
	Lbs.	(kg/25.4mm)	Ft.	(m)	Lbs.	(kg)
AS1	40	18.1	10	3.05	3.1	1.4

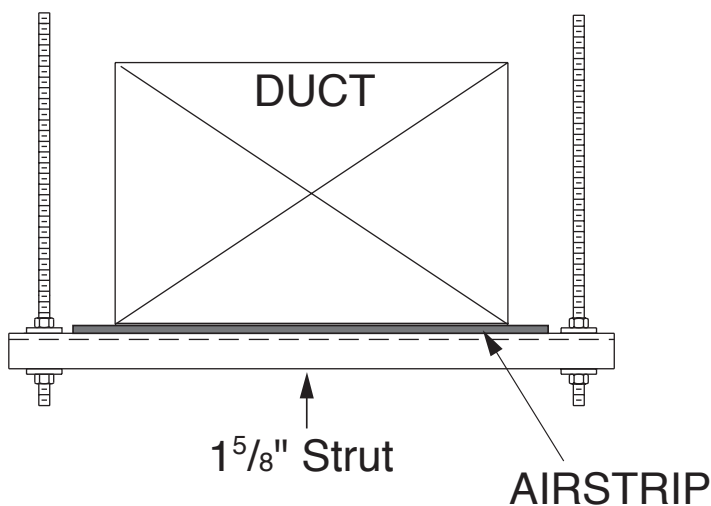
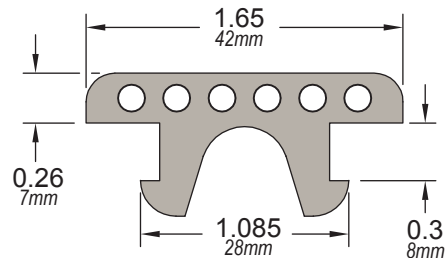

Installs simply by pushing into place

To remove, squeeze the tabs at the end and push up

